

Temperature Calibration

Technical Data



Temperature plays a key role in many industrial and commercial processes. Examples include monitoring cooking temperature in food processing, measuring the temperature of molten steel in a mill, verifying the temperature in a cold storage warehouse or refrigeration system, or regulating temperatures in the drying rooms of a paper manufacturer.

A temperature transmitter will use a measuring device to sense the temperature, and then regulate a 4-20 mA feedback loop to a control element that affects the temperature (Fig. 1). The control element might consist of a valve that opens or closes to allow more steam into a heating process or more fuel

to a burner. The two most common types of temperature sensing devices are the thermocouple (TC) and resistive temperature detector (RTD).

Fluke provides a broad range of temperature calibration tools to help you quickly and reliably calibrate your temperature instrumentation. A summary of the temperature calibration capabilities of Fluke Process Tools is shown below.

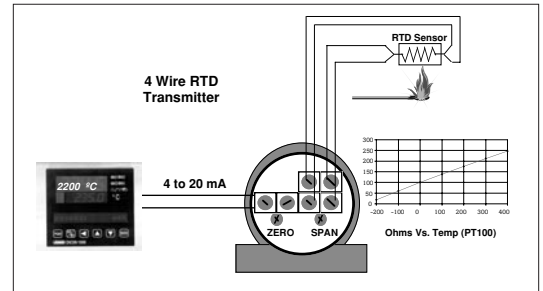

Figure 1.

Fluke 724 Temperature Calibrator

Fluke Temperature Test Tools	Fluke 712	Fluke 714	Fluke 724	Fluke 725	Fluke 741	Fluke 743	Fluke 744	Fluke 55XX	Fluke 50 Series
Function									
Measure temperature from an RTD probe	•		•	•	•	•	•	•	
Measure temperature from a T/C probe		•	•	•	•	•	•	•	•
Simulate an RTD output	•		•	•	•	•	•	•	
Simulate an RTD into pulsed excitation current							•		
Simulate a T/C output		•	•	•	•	•	•	•	
Simultaneous output a T/C, measure mA			•	•	•	•	•		
Simultaneous output an RTD, measure mA			•	•	•	•	•		
Log a temperature measurement						•	•		•
Ramp a temperature signal			•	•	•	•	•		
Loop power supply			•	•	•	•	•		
Multifunction Source and Measure				•	•	•	•		
Automatically calibrate temperature switches					•	•	•		
Electronic data capture					•	•	•		
Upload documented data to PC						•	•		
Integrated HART communication							•		

Typical Temperature Calibration Applications

How to calibrate a Thermocouple input transmitter

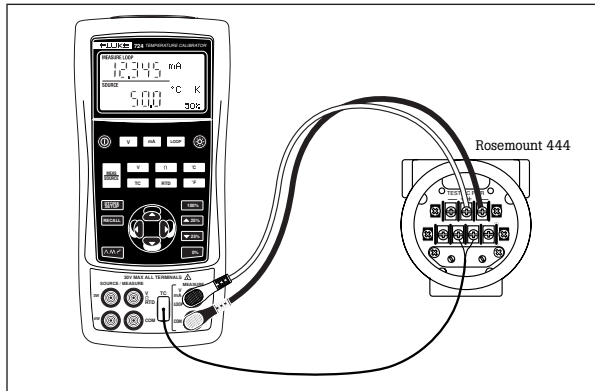

The Fluke 724 Temperature Calibrator can provide the three things necessary to calibrate a temperature transmitter. You can source a temperature, provide loop power, and measure the resulting output current. The following example shows how to calibrate a Type K TC transmitter that is ranged from 0-150 degrees centigrade, generating an output current range from 4-20 mA.

Basic Calibrator Setup

1. Connect the 724 test leads to the TC transmitter as shown. The output from the thermocouple jacks on the 724 will simulate a temperature input to the transmitter. The red and black test leads will provide loop power to the transmitter and will measure the current resulting from temperature changes into the transmitter.
2. Power on the 724 calibrator. Select the mA button and the LOOP button to select measure milliamps with 24V loop power applied.

3. Press the Meas/Source button until the lower portion of the 724 display indicates the source mode.
4. Depress the TC button until a TC type of K is displayed.
5. Select the °C button for centigrade.
6. Set the Zero Point for this application into the Calibrator. To do this set the display initially to 0.0°C. You can use the up and down arrow keys to change the output value. Use the left and right arrows to control which decade value of the display is being changed. When the display reads 0.0, hold down the 0% key on the 724 and observe that 0% is displayed in the lower right corner of the screen. This establishes the Zero point for calibration.
7. Set the Span Point in the Calibrator. Set the display to the desired Span value for calibration. In this example the display should read 150°C. Depress the 100% key and observe that 100% is displayed in the lower right corner of the screen. This establishes the Span point for calibration.

Performing an "As Found" Test

8. Depress the 0% key; record the applied temperature and the corresponding mA measurement.
9. Depress the 25% key (2) times; record the applied temperature and the corresponding mA measurement.
10. Depress the 100% key; record the applied temperature and the corresponding mA measurement.
11. Calculate the errors for each of the (3) points using the following formula: **ERROR = $\frac{I - 4}{16} - \frac{T - 0}{TSPAN} \times 100$** where Error is in % of span, I is your recorded mA measurement, T is the recorded temperature and TSPAN is the temperature input span (100% - 0% points). The error calculation table below shows how to apply the formula to actual recorded measurements.
12. If your calculated errors are less than the specified instrument tolerance, the transmitter has passed the As-Found test. If the test has not passed, perform adjustments as necessary.

Adjusting the Transmitter

13. Depress the 0% key to source the proper temperature for a 4 mA output. Adjust the zero potentiometer until the current reading is 4.00 mA.
14. Depress the 100% key to source the proper temperature for a 20 mA output. Adjust the Span potentiometer until the current reading is 20.00 mA.
15. Depress the 0% key again and adjust the zero potentiometer again if necessary, to get a 4.00 mA output.

Perform an "As Left" Test

Repeat steps 8 through 12 to complete the full calibration procedure on your temperature transmitter.

Temperature transmitter error calculation example

mA Measurement	TC Source	T Span	Formula	Error %
4.02	0°C	150°C	$\frac{4.02 - 4}{16} - \frac{0 - 0}{150} \times 100$	0.1250
11.95	75°C	150°C	$\frac{11.95 - 4}{16} - \frac{75 - 0}{150} \times 100$	-0.3125
20.25	150°C	150°C	$\frac{20.25 - 4}{16} - \frac{150 - 0}{150} \times 100$	1.5625

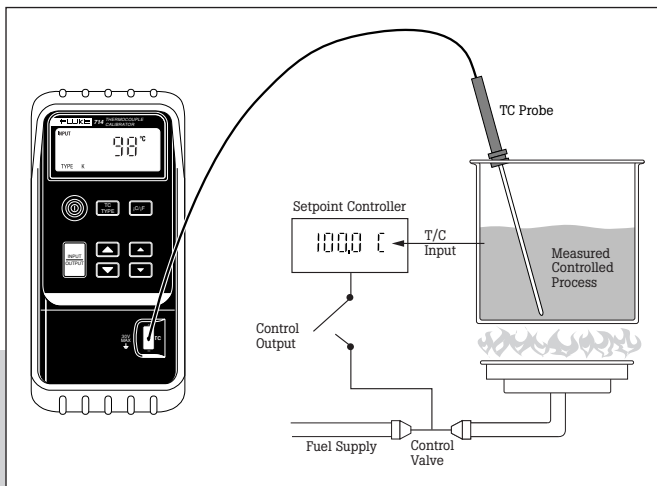

Measuring temperature

Process temperatures can be verified using a temperature calibrator or digital thermometer. In this example, both the controller/indicator and its' input sensor can be verified at the process operating temperature.

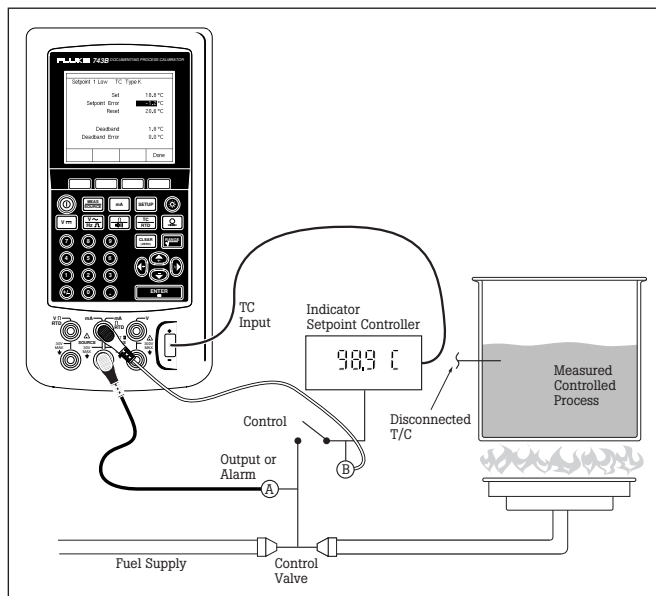

Verifying thermostat or temperature controllers

The performance of a thermostat or temperature controller can be determined by measuring the outputs while applying a temperature signal to the input. In this example, a Fluke 740 series calibrator simultaneously varies the input signal while monitoring contact closure on the output. The calibrator then documents the measured setpoint, reset point and deadband size. See the Limit Switch application note, listed on page 7, for more information on switch testing.

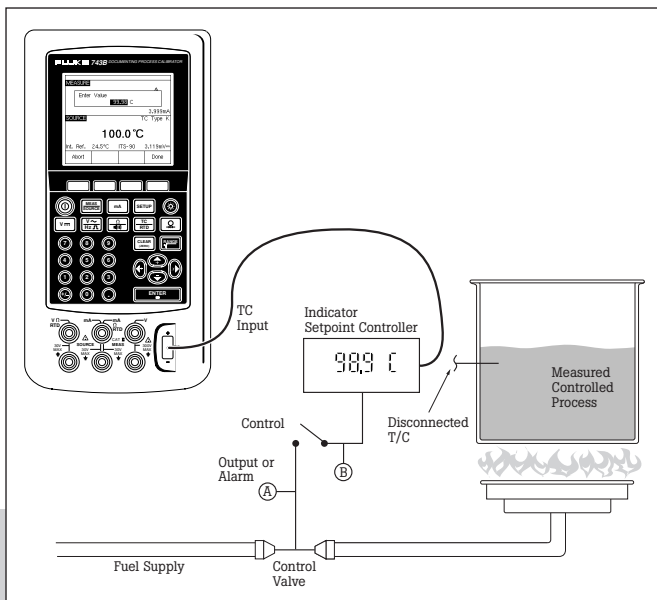

Sourcing Temperature, documented indicator verification

The performance of a temperature indicator can be verified by applying a calibrated signal to the sensor input and noting the results. The performance of the indicator can be documented using the 740 series calibrators by entering the indicator value using the keypad. Please see the Custom Units/User Entered Values application note, listed on page 7, for more information and instructions.

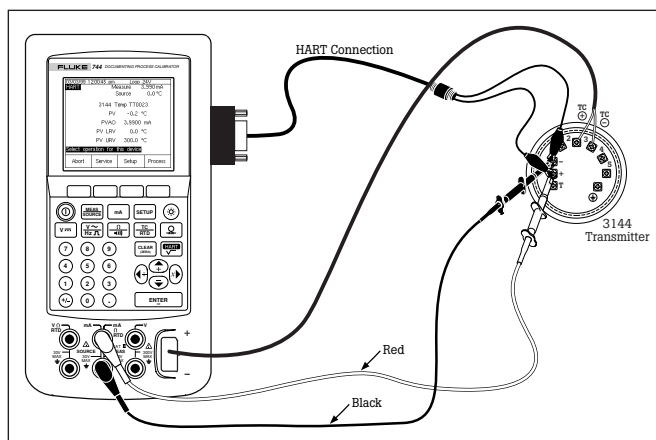

Calibrate a HART Temperature Transmitter

HART "smart" transmitters require digital adjustment if found to be out of specification. This task requires a precision calibrator and a digital configuration tool. The Fluke 744 shown is connected to a Rosemount 3144 HART temperature transmitter. In this configuration, the 744 applies a T/C simulation signal and measures the mA output and digital PV. If adjustment is necessary, sensor trim, output trim and re-ranging can be performed with the Fluke 744. See the HART application note, listed on page 7.



Fluke 741, 743 and 744 Documenting Process Calibrators

- Measure or simulate JKTERSBLUNC thermocouples
- Measure or simulate 7 RTD types, per 712 below, plus Cu 10 (47)
- Source or measure volts, ohms, mA, frequency
- Measure pressure with Fluke 700Pxx Pressure Modules
- Electronically capture results of automated procedures
- Serial communication to PC (743, 744)
- HART communication (744)



Fluke 725 Multifunction Process Calibrator

- All the temperature capabilities of Fluke 724 below, plus:
- Measure pressure with Fluke 700Pxx Pressure Modules
- Source or measure frequency to 10 kHz
- Source mA signals



Fluke 724 Temperature Calibrator

- Measure or simulate JKTERS BLUN thermocouples
- Measure or simulate 7 RTD types (see 712)
- Measure or source VDC, Ω
- Measure 24 mA, with or without 24 volt loop supply
- Source TC or RTD while measuring V or mA
- Handles pulsed RTD transmitters with pulses >5 ms



Fluke 712 RTD Calibrator

- Measure or simulate Pt 100 200 500 1000 (385), Pt 100 (3926), Pt 100 (3916) and Ni 120 (672)
- Measure or source 15 Ω to 3200 Ω
- Handles pulsed RTD transmitters
- Selectable °F or °C
- Banana jacks for 2W, 3W or 4W measurements



Fluke 714 Thermocouple Calibrator

- Measure or simulate JKTER SBLU thermocouples
- Measure or source -10 to 75 mV
- Selectable °F or °C
- Thermocouple mini-jack termination



Fluke 51 Single Input Digital Thermometer



Fluke 52 Dual Input Digital Thermometer



Fluke 53 Single Input Digital Thermometer with data logging



Fluke 54 Dual Input Digital Thermometer with data logging

Fluke 51 Series II and 52 Series II

- Large backlit dual display shows any combination of T1, T2 (52 only), T1-T2 (52 only), plus MIN, MAX, or AVG
- Relative time clock on MIN, MAX, and AVG provides a time reference for major events.
- Electronic Offset function allows compensation of thermocouple errors to maximize overall accuracy
- Measures J, K, T, and E-types of thermocouples
- Readout in °C, °F, or Kelvin (K).

The Fluke 53 Series II and 54 Series II

- Include all the features listed for the 51 and 52 Series II plus:
- Data Logging up to 500 points of data with user adjustable recording interval
 - Additional thermocouple types R, S, and N (for a total of 7 different types)
 - Real time clock captures the exact time of day when events occur
 - Recall function allows logged data to be easily reviewed on the meter display
 - IR communication port allows data to be exported to optional FlukeView® Temperature PC software for further analysis and graphing



61 Infrared Thermometer

- Easy to use
- Quick non-contact temperature measurements from -18 to 275 °C (0 to 525 °F)
- 0.2 °C or 0.5 °F resolution
- Backlight illuminates the display in the dark
- Laser-sighted; 8:1 optical resolution



65 Infrared Thermometer

- Range -40 to 500°C (-40 to 932°F)
- 0.1° resolution up to 200°
- Measurements in less than 1 second
- Bright laser beam for easy targeting
- 8:1 Optical Resolution
- MIN/MAX reading capture
- Large backlit dual display



2620T/2635T Recording Thermometers

- 20 channel precision thermometer with SPRT Reference Probe
- Up to 18 channels TC Calibration System
- Up to 9 channels RTD Calibration System
- NIST/DKD certified calibration to ±.05°C

Temperature Test Tool Summary Performance: Selected examples

744	743/743B	741/741B	725	724	714	712	53/54	51/52	Function	Range	Resolution	Accuracy	Notes
•	•	•							RTD PT100-385	Measure -200 to 800°C Simulate -200 to 800°C	0.1°C	0.3°C	8 RTD types
			•	•		•			RTD PT100-385	Measure -200 to 800°C Simulate -200 to 800°C	0.1°C 0.1°C	0.33°C 0.33°C	7 RTD types
•	•	•							Resistance 100Ω range	Measure 0-11,000Ω Simulate 0-11,000Ω	.01Ω .01Ω	.05% + 50 mΩ .01% + 40 mΩ	
			•	•		•			Resistance 100Ω range	Measure 15-3200Ω Simulate 15-3200Ω	.1Ω .1Ω	.1Ω to 1Ω .1Ω to 1Ω	
•	•	•							Thermocouple Type K	Measure -202 to 1374°C Simulate -202 to 1374°C	0.1°C 0.1°C	0.3°C 0.3°C	JKTERSBLUNC
							•		Thermocouple Type K	Measure -200 to 1372°C	0.1°C <1000°C 0.1°C >1000°C	0.05% rdg + 0.3°C	JKTERS N
							•		Thermocouple Type K	Measure -200 to 1372°C	0.1°C <1000°C 0.1°C >1000°C	0.05% rdg + 0.3°C	JKTE
			•	•	•				Thermocouple Type K	Measure -200 to 1370°C Simulate -200 to 1370°C	0.1°C 0.1°C	0.3°C + 10 μV 0.3°C + 10 μV	JKTERSBLU plus N on 724, 725
•	•	•							mV	Measure 0-110 mV Source 0-110 mV	.001 mV .001 mV	.25% + .015% FS .01% + .005% FS	
			•	•	•				mV	Measure -10 to 75 mV Source -10 to 75 mV	.01 mV .01 mV	.025% + 1 count .025% + 1 count	
			•	•					Measure mA	0-24 mA	.001 mA	.020% + 2 count	
•	•	•							Measure mA	0-24 mA	.001 mA	.010% + .015% FS	
•	•	•	•	•					Loop Power Supply	24V dc	n/a	± 10%	

Temperature Terminology

Dry Well Calibrator: A temperature calibrator that uses a precision oven to source precise temperature. This style of calibrator is often used for the verification of temperature sensors.

Excitation current: A constant current applied to an RTD probe to determine actual resistance for temperature measurement. Typical values are 2 mA or less to minimize self-heating of the probe.

IPTS-68: International Practical Temperature Scale of 1968. A temperature standard adopted in 1968 that uses intrinsic standards to define the measurement of temperature.

ITS-90: International Temperature Scale of 1990. A temperature standard adopted in 1990 that uses intrinsic standards to define the measurement of temperature. This standard modifies the intrinsic standards of IPTS-68 with additional intrinsic references.

Lead Resistance Compensation: A compensation method used with 3 and 4 wire RTDs and resistance measurement. This method negates the error associated with lead resistance when making an RTD measurement.

Reference Temperature: The temperature at which a thermocouple temperature measurement is referenced. For Fluke Calibration tools, this is the temperature where the thermocouple mini-plug is connected to the calibrator.

R₀: The resistance value of an RTD probe at 0°C. Example PT100-385, R₀ = 100Ω.

RTD: Resistance Temperature Device, a temperature measurement sensor that has predictable changes in resistance with a change in temperature. The most common RTD is the platinum PT100-385.

Seebeck Effect: Thermoelectric effect in which the voltage potential increases with temperature (thermocouples) in a junction of dissimilar metals.

Triple point of water: This temperature reference point is the intrinsic standard at which water is liquid, ice and gas. This reference point defines 0.01°C.

Thermocouples

Plug Color	Alloys		Fluke 700 Series DPCs	
	+	-	Temperature Range	EMF Range
White B	Pt-30% Rh Platinum-30% Rhodium	Pt-6% Rh Platinum-6% Rhodium	600 to 1820°C, 1112 to 3308°F	1.792 to 13.820 mV
Red C	W-5% Re Tungsten-5% Rhenium	W-26% Re Tungsten-26% Rhenium	0 to 2316°C, 32 to 4201°F	0 to 37.079 mV
Purple E	Ni-Cr Nickel-Chromium (Chromel)	Cu-Ni Copper-Nickel (Constantan)	-250 to 1000°C, -418 to 1832°F	-9.719 to 76.370 mV
Black J	Iron Fe	Cu-Ni Copper-Nickel (Constantan)	-210 to 1200°C, -346 to 2193°F	-8.096 to 69.555 mV
Yellow K	Ni-Cr Nickel-Chromium (Chromel)	Ni-Al Nickel-Aluminum	-200 to 1372°C, -328 to 2502°F	-5.891 to 54.886 mV
Blue L	Fe Iron	Cu-Ni Copper-Nickel (Constantan)	-200 to 900°C, -328 to 1652°F	-8.166 to 53.147 mV
Orange N	Ni-Cr-Si Nickel-Chromium-Silicon (Nicrosil)	Ni-Si-Mg Nickel-Silicon-Magnesium (Nisil)	-200 to 1300°C, -328 to 2372°F	-3.990 to 47.514 mV
Green R	Pt-13% Rh Platinum-13% Rhodium	Pt Platinum	-20 to 1767°C, -4 to 3213°F	-0.101 to 21.089 mV
Green S	Pt-10% Rh Platinum-10% Rhodium	Pt Platinum	-20 to 1767°C, -4 to 3213°F	-0.103 to 18.682 mV
Blue T	Cu Copper	Cu-Ni Copper-Nickel (Constantan)	-250 to 400°C, -418 to 752°F	-6.181 to 20.873 mV
White U	Cu Copper	Cu-Ni Copper-Nickel	-200 to 600°C, -328 to 1112°F	-5.693 to 34.320 mV

Temperature Conversion

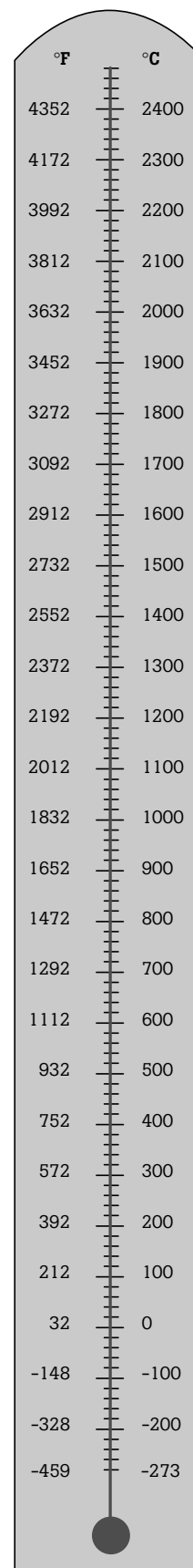

Fixed Points of ITS-90

- 961.78°C Silver freezing point
- 660.323°C Al freezing point
- 419.527°C Zinc freezing point
- 231.928°C Tin freezing point
- 156.5985°C Indium freezing point
- 29.7646°C Gallium melting point
- 0.01°C H₂O triple point
- 38.8344°C Mercury triple point
- 189.3442°C Argon triple point
- 218.7916°C Oxygen triple point
- 248.5939°C Neon triple point
- 259.3467°C Hydrogen triple point

Application Assistance

To request copies of these application notes, contact your Fluke sales organizations.

- Understanding Specifications (pub ID 10127)
- Transmitter Calibration (pub ID 10123)
- HART Transmitter Calibration (pub ID 10179)
- Limit Switches (pub ID 10121)
- Pressure Modules (pub ID 10188)
- Loop Calibration (pub ID 10437)

Temperature Accessories

Fluke 700TC1 Thermocouple Mini-Plug Kit (11 types)

For use with: Fluke 700, 720 or 740 Series Process Calibrators, Fluke 714 Thermocouple Thermometer.
Description: A kit of 10 mini-plug connectors:

- Type J (black), one
- Type K (yellow), one
- Type T (blue), one
- Type E (purple), one
- Type R/S (green), one
- Type B or Cu (white), one
- Type L (J-DIN) (blue), one
- Type U (T-DIN) (brown), one
- Type C (red), one
- Type N (orange), one

Fluke 700TC2 Thermocouple Mini-Plug Kit Type J, K, T, E, R/S

For use with: Fluke 700, 720 or 740 Series Process Calibrators, Fluke 714 Thermocouple Thermometer.

Description: A kit of seven mini-plug connectors:

- Type J (black), two
- Type K (yellow), two
- Type T (blue), one
- Type E (purple), one
- Type R/S (green), one

80T-IR Non-Contact Infrared Temperature Probes

For quick, non-contact temperature measurement in less than one second

- Instantly measures temperatures from -18° C to 260° C (0 to 500° F)
- Highly repeatable readings displayed in °C or °F
- Optical resolution 4:1
- Output 1mV/°C or 1mV/°F (switch selectable)

80T-IR/E Extended Range, Non-Contact Infrared Temperature Probe

Special version of the 80T-IR:

- Extended range: 0 to 1,000 °F
- Measures °F only (no °C)

80TK Thermocouple Module

Converts multimeters with a mV range into digital thermometers.

- Converts K-type thermocouple signals into mV output.
- Connects to DMM via standard banana plugs
- Switch selectable °C or °F
- Range: -50° C to 1000° C (-58 to 1832° F)

Infrared Temperature Probe - 80PK-IR

Compatible with Fluke 714, 724, 725, 74X, Fluke 50 Series thermometers, Fluke 16 and 89 IV DMMs, this probe measures the temperature of objects that can't be touched.

- Measurement range: -18 to 260° C (0 to 500° F)

General Purpose Bead Probes 80PK-1 and 80PJ-1

Basic, inexpensive thermocouple. Good accuracy and fast response. (Not suitable for liquid immersion.)

- 80PK-1 for K-type thermometers; 80PJ-1 works for J-Type thermometers
- Measurement range: -40 to 260° C (-40 to 500° F)

K-Type Immersion Probe - 80PK-2A

General-purpose probe including liquids and gels.

- Measurement range: -40 to 982° C (-40 to 1800° F)

K-Type Flat Surface Probe - 80PK-3A

Measure the temperature of flat or slightly convex surfaces, such as hot rollers and plates.

- Exposed junction for direct contact with surface
- Measurement range: 0 to 260° C (32 to 500° F)

K-Type Air Probe 80PK-4A

For air and non-caustic gas applications.

- Probe of 304 stainless steel with perforated baffle around the bead
- Measurement range: -40 to 816° C (-40 to 1500° F)

Piercing Probes - 80PK-5A and 80PT-5A

Designed for foods, liquids and gels.

- Probe made of 304 stainless steel
- 80PK-5A is compatible with K-Type instruments; 80PT-5A is designed for use with T-Type thermometers
- Measurement range: -40 to 260° C (-40 to 500° F)

K-type Exposed Junction Probe - 80PK-6A

Use both as a surface probe and for insertion into air and non-corrosive gases.

- Probe made of 304 stainless steel
- Measurement range: -40 to 816° C (-40 to 1500° F)

K-Type Industrial / Heavy Duty Surface - Probe - 80PK-7

For flat or slightly curved surfaces.

- Exposed junction allows direct contact with the surface being measured
- Rugged design for extended service life
- Measurement range: -127 to 600° C (-196° F to 1112° F)

K-Type Probe Pipe Clamp Temperature Probe-80PK-8

Designed for pipes from 6.4 mm (1/4") diameter to 34.9 mm (1-3/8") diameter.

- Measurement range: -29° C to 149° C (-20° F to 300° F)

General Purpose Probes - 80PK-9 and 80PJ-9

Use as surface probe and for insertion into air and non-caustic gases.

- Probe constructed of 304 stainless steel
- 80PK-9 is compatible with K-type thermometers; 80PJ-9 operates with J-Type
- Measurement range: -40 to 260° C (-40 to 500° F)

Extension Wire Kits - 80PK-EXT, 80PJ-EXT and 80PT-EXT

For extending and repairing J, K or T-type thermocouple wires.

- Kit includes 3 meters of thermocouple wire and 1 pair of male/female mini-connectors
- Maximum continuous exposure temperature: 260° C (500° F)

Fluke. *Keeping your world up and running.*

Fluke Corporation

PO Box 9090, Everett, WA USA 98206

Fluke Europe B.V.
PO Box 1186, 5602 BD
Eindhoven, The Netherlands

For more information call:

U.S.A. (800) 443-5853 or
Fax (425) 446-5116
Europe/M-East/Africa
(31 40) 2 675 200 or
Fax (31 40) 2 675 222
Canada (800) 36-FLUKE or
Fax (905) 890-6866
Other countries +1 (425) 446-5500 or
Fax +1 (425) 446-5116

Web access: <http://www.fluke.com>